



## ORDER PICKER

# V 15

## 3,000 lbs. Capacity

### Series 5215

- The Series 5215 utilizes 100% AC Motor Technology along with the latest controls allows the operator to smoothly operate the truck
- Operators benefit from sealed critical harness connections and solid-state components
- Linde's well known ergonomic controls provide a sure grip increasing operator productivity and confidence
- A one-piece low profile design cover requires no tools and provides better visibility and full access to key components
- CAN-bus design and diagnostics can be controlled through a single point plug and fault codes can be easily displayed

# STANDARD & OPTIONAL EQUIPMENT

## STANDARD

- Heavy duty pallet clamp opening range 1" to 5.4"
- 42" x 27" operator platform
- 42" x 1.5" x 4" standard tapered forks
- 13.5" x 5.3" polyurethane drive tire
- 5" x 4" articulating tandem load wheels
- 38.7" x 14.6" x 32" height battery compartment
- 24V electrical system
- Standard construction
- 42" outside dimension (base width basearms)
- UL classification type "E"
- Key switch start
- Steering returns to center upon start
- Curve control
- Powered lowering
- Stationary multi-function control handle
- Operator sensor in handle
- Proportional lift with regenerative lowering
- Large surface electrical park brake / automatically engaged / foot release
- Wide opening pallet clamp automatically engaged foot control
- High-level operation restricted speed and steer angle < 10°
- AC traction / hoist / steering
- Single hydraulic pump and motor
- CAN bus communications
- Electric power steering with auto-center at startup
- Auto deceleration with regenerative braking
- LCD multi-function display with back lighting
- Hour meters: truck, traction, and hoist pump
- Battery discharge indicator with lift interrupt
- Steer drive unit wheel angle indicator
- Truck speed in mph or km/h
- LED indicators with symbols
- SB 350 "Red" battery conductor
- Programmable travel speeds
- Slack chain indicators
- Cantilevered overhead guard
- Low step height
- Protective wire mesh mast guard
- Hoop-style stationary platform gates
- Battery power disconnect button
- Operator storage compartment with removable bins
- Full body harness and retractable tether
- Electric horn
- Static strap
- Fixed clipboard
- Beverage holder
- Battery rollers
- Chassis-mounted flashing beacon
- Operating manual - English

## OPTIONAL

- 36V electrical system
- UL classification "EE"
- Pin code / toggle switch
- Environmental construction
  - Cooler freezer conditioning -26°F - 110°F
  - Corrosion
  - Food grade
- Safety glass shield
- Retractable side gates with traction cutout
- 4" vertical adjustable (Electric) operator console / work station
- Various mast options available
- Fork option lengths available
- Lift limit
- Lift limit with push-button override
- Various drive tire options
- Operator platform widths 42", 48", 54", 60"
- Wire guidance
- Rail guidance
- Various light / convenience packages
  - Cabin light
  - Two lateral lights
  - BlueSpot™ activated forward
  - BlueSpot™ activated reverse
  - One light to shine on load
- DC to DC converter - 25 amps / 400 watts at 12 volts
- Motion alarm forward and reverse
- Motion alarm when operation timed out
- Parts manual
- Polycarbonate mast protection
- Various battery connector colors

Mast Dimensions			
	Maximum Fork Height	Overall Lowered Height	Overall Extended Height
	in. (mm)	in. (mm)	in. (mm)
3-Stage	192.7" (4895)	90.7" (2304)	281.7 (7155)
	210.4" (5344)	96.6" (2454)	299.4 (7605)
	240.0" (6096) max for VOP15B	106.5" (2705)	329.0 (8357)
	265.5" (6744)	118.3" (3005)	354.0 ( 8992)
	295.0" (7493) max for VOP15P	128.1" (3254)	384.0 (9754)
	312.8" (7945)	134.0" (3404)	401.8 (10205)
	332.5" (8446)	149.8" (3805)	421.5 (10706)
	350.2" (8895)	155.7" (3955)	439.2 (11156)
	362.0" (9149) max for VOP15HP	159.6" (4054)	451.0 (11455)



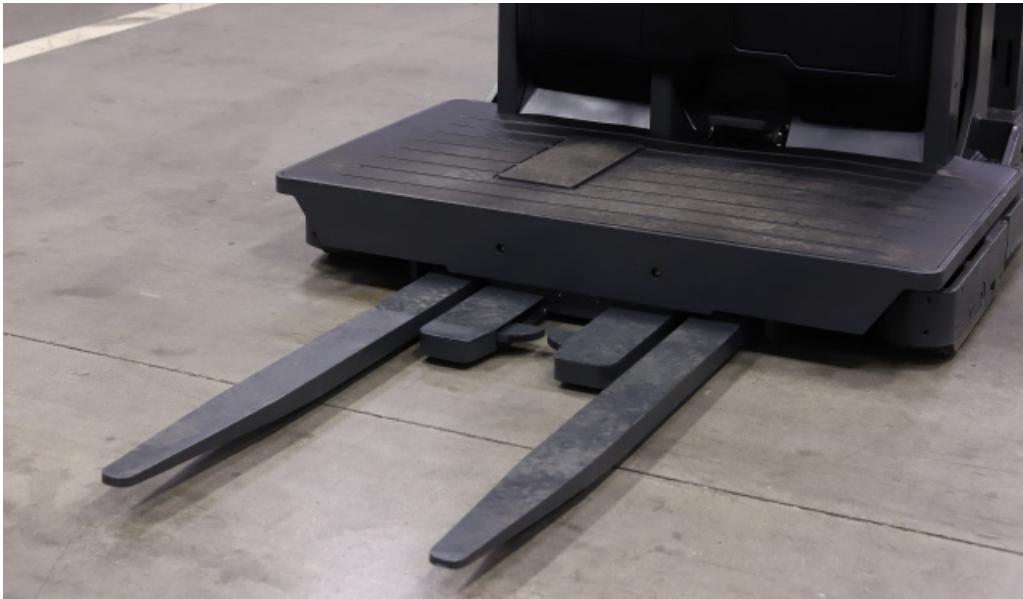

# V15 TECHNICAL DATA

February 2020

Characteristics					LINDE				
					V15 - 24V		V15 - 36V		
					Battery				
1.1	Manufacturer								
1.2	Manufacturer's model designation								
1.3	Power unit								
1.4	Operation				Order Picker				
1.5	Load capacity	Q	lbs	kg	2998.3	1360	3000	1360	
1.6	Load center	c	in	mm	23.6	600	24	600	
1.9	Wheelbase	y	in	mm	56.1	1425	56.1	1425	
Weights	2.1	Service weight		lbs	kg	7562	3430	9480	4300
	2.2	Axle loadings with load front / rear		lbs	kg	2249/8422	1020/3820	3064/9546	1390/4330
	2.3	Axle loadings without load front / rear		lbs	kg	4222/3340	1915/1515	5159/4321	2340/1960
Wheels	3.1	Tires			Polyurethane				
	3.2	Tire size, front		in	mm	13.5x5.3	343x135	13.5x5.3	343x135
	3.3	Tire size, rear		in	mm	4.9x4.1	125x105	4.9x4.1	125x105
	3.5	Wheels, number front / rear (x=driven)				1x/4		1x/4	
	3.6	Track width, front	b <sub>10</sub>	in	mm	0	0	0	0
	3.7	Track width, rear	b <sub>11</sub>	in	mm	36.8	935	54.4	1382
	Dimensions	4.2	See mast chart			See mast chart			
4.8		Height of seat / stand-on platform	h <sub>7</sub>	in	mm	8.3	210	8.3	210
4.14		Platform height, raised	h <sub>12</sub>	in	mm	245.7	6240	367.7	9340
4.15		Fork height lowered	h <sub>13</sub>	in	mm	3	75	3	75
4.19		Overall length	l <sub>1</sub>	in	mm	118.9	3020	118.9	3020
4.20		Length to fork face	l <sub>2</sub>	in	mm	76.6	1945	76.6	1945
4.21		Overall width	b <sub>1</sub> /b <sub>2</sub>	in	mm	42.4/42.4	1077/1077	42.4/60.0	1077/1524
4.22		Fork dimensions	s/e/l	in	mm	1.6x3.9x42.1	40x100x1070	1.6x3.9x42.1	40x100x1070
4.24		Width of fork carriage	b <sub>3</sub>	in	mm	30.8	782	30.8	782
4.25		Fork spread, min. / max.	b <sub>5</sub>	in	mm	28.1/24.2	715/615	28.1/24.2	715/615
4.27		Width over side guider rollers	b <sub>6</sub>	in	mm	49	1245	67	1702
4.31		Ground clearance, mast	m <sub>1</sub>	in	mm	1.7	42	1.7	42
4.32		Ground clearance, center of wheelbase	m <sub>2</sub>	in	mm	2.8	70	2.8	70
4.35		Turning radius	W <sub>a</sub>	in	mm	66.9	1700	70.9	1800
Performance	5.1	Travel speed, with / without load		mph	kmh	7.8/7.8	12.5/12.5	7.8/7.8	12.5/12.5
	5.2	Lift speed, with / without load		fpm	m/s	0.23/0.38		0.41/0.53	
	5.3	Lowering speed, with / without load		f/m	m/s	0.4/0.4		0.4/0.4	
	5.10	Service brakes		s		Regenerative		Regenerative	
Drive	6.4	Battery voltage / rated capacity		V/Ah		24/750		36/625	
	6.5	Battery weight (min)		lbs	kg	1444	655	1841	838
Others	8.1	Type of drive				AC Microprocessor		AC Microprocessor	
	8.4	Noise level at operator's ear			dB(A)	<70		<70	

Extended lift heights / maximum fork height may reduce capacity depending on OEC dimensions.

**NOTICE:** Our products are continuously being improved; all conditions, terms, and specifications are subject to change at any time.

BATTERY COMPARTMENT				
Voltage	Battery Compartment Dimensions			Min.Weight Required
	"x" (width)	"y" (length)	"z" (height)	
	in. (mm)	in. (mm)	in. (mm)	lbs. (kg)
24	38.7 (982)	14.6 (371)	32 (812.8)	1444 (655)
36	38.7 (982)	14.6 (371)	32 (812.8)	1847 (838)

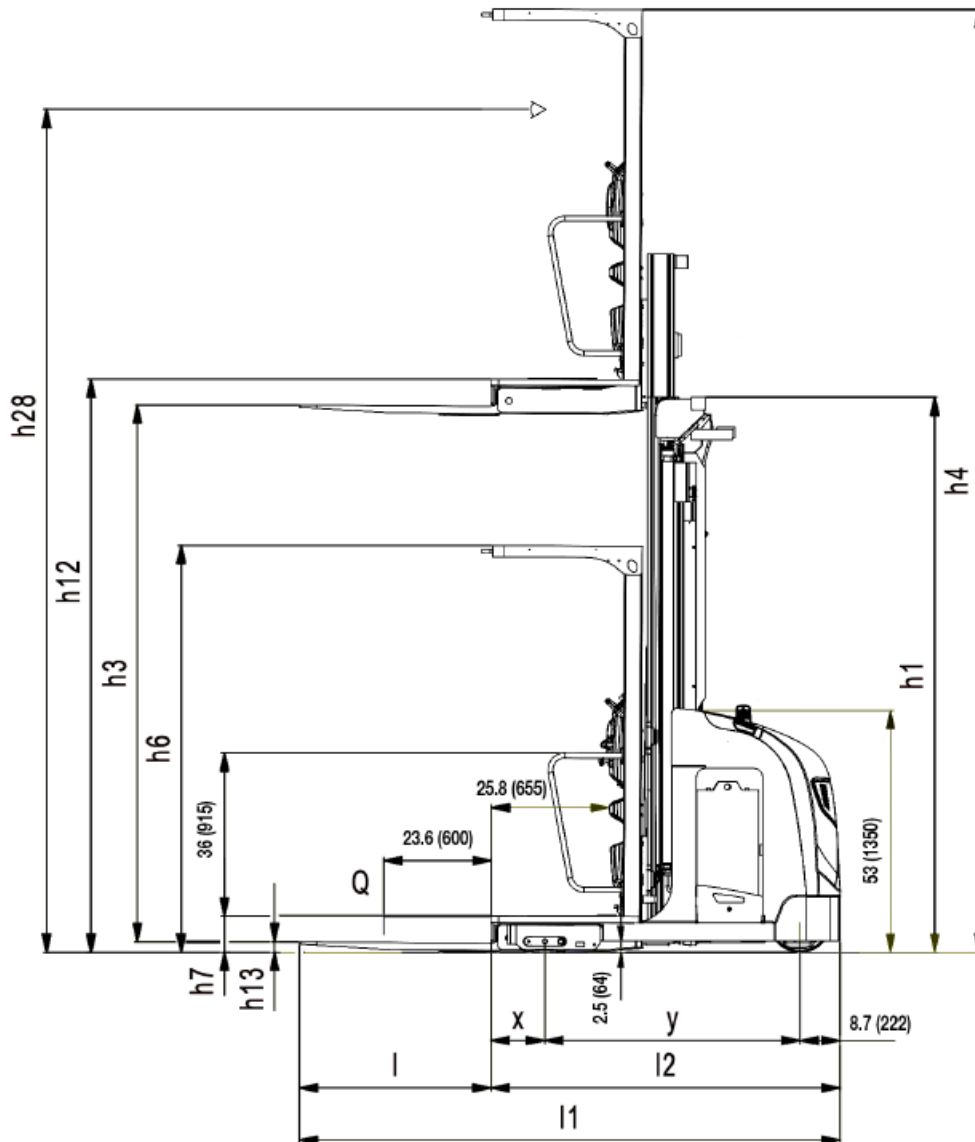
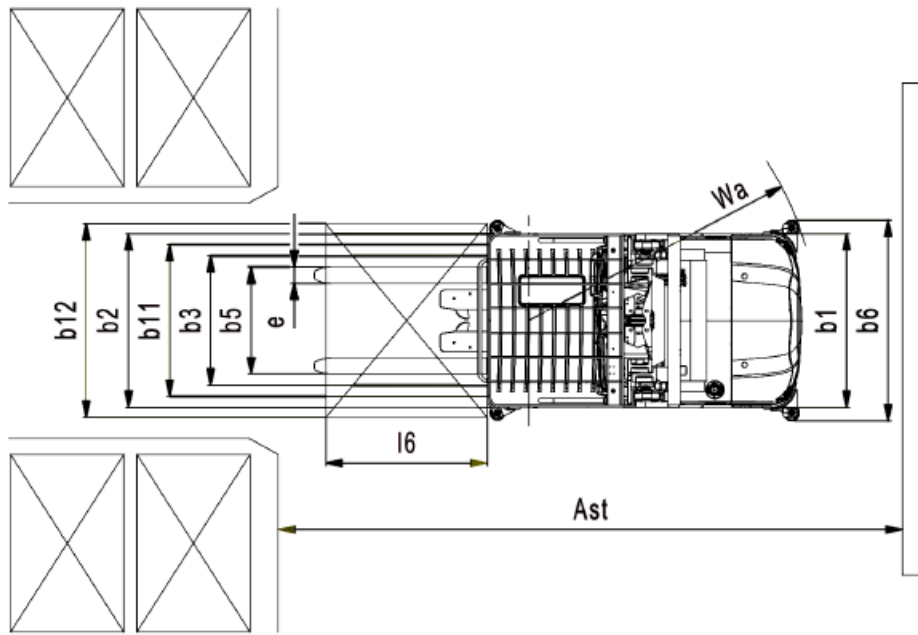

\*Refer to Technical Data Chart

# FEATURES



Operator Comfort



Curve Control



Unique Clamp Design

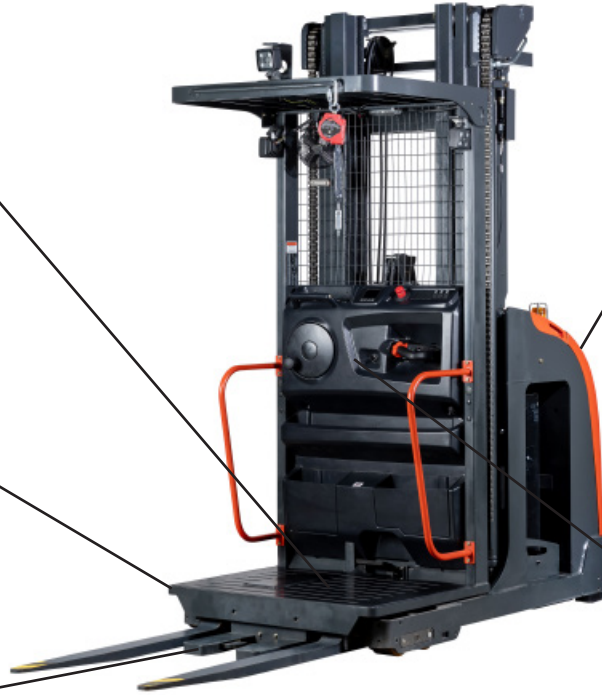

Open Access to Components



Control Handle

## Linde Series 5215 Five Features

- **Operator Comfort:** Large operator compartment, foot room, and brake area with a premium floor mat to ensure enough space to comfortably change foot positioning throughout the day.
- **Open Access to Components:** Full access to key components is achieved without tools and directly in front of technician.
- **Curve Control:** Linde curve control automatically reduces driving speed depending on steering angle, ensuring an extra level of safety.
- **Unique Clamp Design:** Automatically clamps and centers pallets with any stringer, ranging from 1" to 5", eliminating the need for standardization of pallets or the use of workarounds.
- **Control Handle:** The multi-function control handle is stationary, allowing a solid 4-point stance position in the operator compartment with the use of a thumb tiller to travel. This handle has eliminated any wrist movements while keeping the operator feeling attached to the truck at all times.









For more information on Linde Material Handling equipment, please contact:

KION North America Corporation  
2450 West 5th North Street, Summerville, SC 29483  
Phone: (843) 875.8000 Truck Sales Fax: (843) 875.8471  
Email: trucksales.na@kiongroup.com  
www.kion-na.com



ANSI: Standard truck meets all applicable mandatory requirements of ANSI/ITSDF B56.1 standards for powered industrial trucks.  
NOTE: Performance data may vary due to motor and system efficiency tolerances. The performance depicted represents normal values obtained under typical operating conditions. Metric dimensions are in millimeters unless otherwise specified. All metric dimensions are not direct equivalents due to rounding data. The descriptions and specifications included on this data sheet were in effect at the time of printing. KION North America Corporation reserves the right to make improvements and changes in specification or design without notice and without incurring obligation. Please check with your authorized Linde dealer for information on possible updates or revisions.

linde\_spec\_5215\_8pg\_20200210